

Primo Vert

The new standard for quick assessment and inspection of living cells.

The inverted microscope Primo Vert is focused on the essentials:

Excellent optical quality, choice of quality materials with high durability, ease of use and an appealing industrial design – and all this is available at an affordable price.

Primo Vert addresses a wide range of applications: From routine laboratories for life cell inspection to cutting edge research laboratories which require - in addition to research microscopes – some compact and reliable routine microscopes for a quick and efficient check of living cells. Typical applications include e. g. cancer and HIV research, human, animal and plant genetics and cell biology in general.

A number of attractive details are designed to guarantee a quick and reliable handling:

- Automatic light turn-off (in addition to manual on/off-function): Primo Vert switches off the light automatically after 15 minutes – saving energy and protecting the stand

- Modular illumination: HAL or long lasting LEDs
- High quality material: The stage is made of cast aluminum and all operating elements are coated with a special skin-friendly rubber mix
- Universal phase slider for all objectives: For the ease of use there is one phase ring (Ph 1) available for 10x, 20x and 40x – this means no changing phase slider when changing objectives. In short: time-saving and economical
- Increased working distance through easy removal of the condensor, e. g. for roller-bottles
- Objective-indicators for fast identification of magnification.
- Carrying handle on the back
- Attractive industrial design



**Efficient, reliable and affordable:
Primo Vert from Carl Zeiss.**



We make it visible.

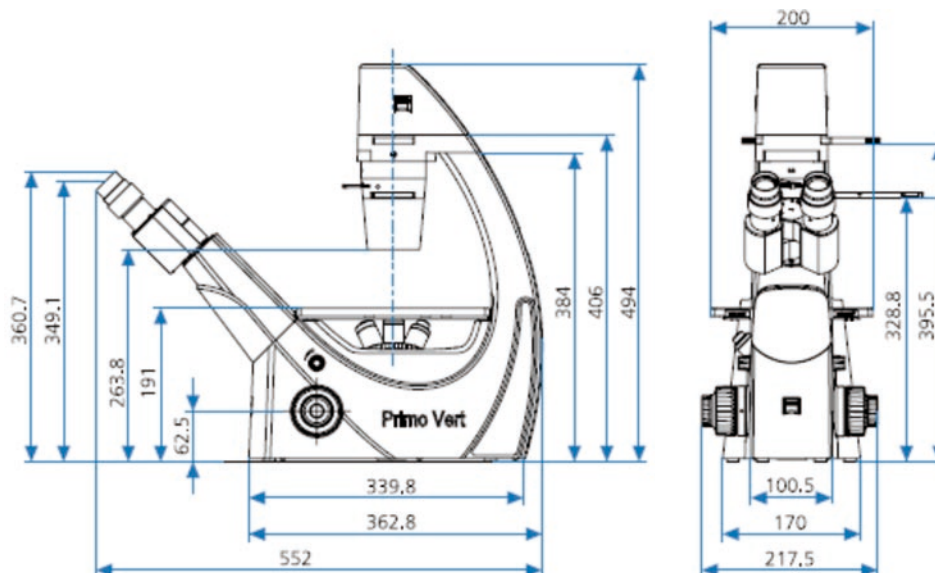

Primo Vert – Optical and Mechanical Data

Objective change	Manual via quadruple objective nosepiece
Objectives	Infinity-corrected objective range with W 0.8 mounting thread Plan-Achromat: 4x/0.1, 4x/0.1 Ph0, 10x/0.25 Ph1 LD-Plan-Achromat: 20x/0.3 Ph1, 40x/0.5 Ph1, 20x/0.3 Ph2, 40x/0.5 Ph 2
Phase-Slider	Universal phase slider for the objectives Ph1: Convenient and economical Phase slider for Ph2: Higher resolution
Eyepieces with field-of-view number 20	30 mm tube diameter W-PL 10x/20 Br. foc.
Specimen stage Dimensions (width x depth)	Fixed 200 x 239 mm
Specimen guide Verniers with numerical and alphabetic scale Coaxial drive	Right side X direction: Numerical scale, readable from right to left Y direction: Alphabetic scale, readable in the mirror right side
LD condenser 0.3	For V_{obj} 4x to 40x, a = 72 mm
LD condenser 0.4	For V_{obj} 4x to 40x, a = 55 mm
Binocular tube 45°/20	
Maximum field-of-view number	20
Interpupillary distance	Adjustable from 48 to 75 mm
Tube angle	45°
Viewing height	360 to 397 mm
Viewing port	Tube factor 1x
Trinocular (photo)tube 45°/20	
Maximum field-of-view number	20
Interpupillary distance	Adjustable from 48 to 75 mm
Tube angle	45°
Viewing height	360 to 397 mm
Viewing port	Tube factor 1x
Photo/video port	Tube factor 1x, 60 mm C-mount
Fixed beam splitting	50 % vis / 50 % doc
Light source	HAL: 6 V, 30 W LED: White light LED



reddot design award
winner 2010

- All optics in Primo Vert are anti-fungus treated
- Norms and standards met: CE, UL, CSA, IvD, DIN EN 61010-1 (IEC 61010-1), ISO 9001
- Available accessories (as option): Object guide and several mounting frames for Petri dishes etc., stage inserts (metal or glass), stage enlargements, several camera adapters, eyepiece micrometer and eyepiece pointer, neutral density and green interference filters, cameras, AxioVision LE microscope software

Carl Zeiss MicroImaging GmbH
07740 Jena, Germany

BioSciences | Göttingen Location
Phone : +49 551 5060 660
Telefax: +49 551 5060 464
E-Mail : micro@zeiss.de

www.zeiss.de/micro